



LEADING
with Innovation



ROTO KWIK PUMPS

Quick Maintenance In Place Pump Technology

Roto KWIK Pumps

Built on the Maintenance in Place (MIP) Platform, Roto KWIK Pumps have been specially designed and developed to provide easy maintenance with minimum service time while saving on overall maintenance costs.

Performance Summary:

| | | | | | |
|----------|---|------------------------------|--------------------|---|------------------|
| Capacity | : | Up to 340 m ³ /hr | Viscosity | : | Up to 30,000 cSt |
| Pressure | : | Up to 24 bar | High Solid Content | : | Up to 7% |

1 Clamp

Specially designed clamp enables quick removal of rotor and stator without dismantling discharge line.

2 Optimised Rotor Stator Geometry

Improved rotor stator geometry minimizes wear due to lower rubbing velocities.

3 Xtra Value Universal Cardan Joint

The Cardan type of UJ joint employs two sets of perpendicular pins, each providing freedom of angular movement, which facilitates smoother transmission of angular loads. It also withstand higher axial loads.



Distinctive Advantages

- Quick maintenance of pumps without dismantling the suction and delivery pipelines.
- One piece construction of stator eliminates any risk of media leakage unlike split stator design.
- Installed Roto Progressive Cavity Pumps can be easily converted to Roto Kwik Platforms with minimal changes in pipeline.
- No need of extra dismantling space.

4 Split Coupling Rod

Enables quick dismantling of pumping elements from the coupling rod.

5 Dual Inspection Windows

Provides access to split coupling rod and also allows removal of any blockage.

5 Quick & Simple Steps To Dismantle Rotor & Stator

Dismantling & re-assembly of the Roto KWIK range of pumps is very simple, a single person can complete the required tasks in a matter of few minutes. It results in significant reduction in maintenance time and labour cost. Maintenance Engineer will need standard tools to dismantle/assemble the pump.

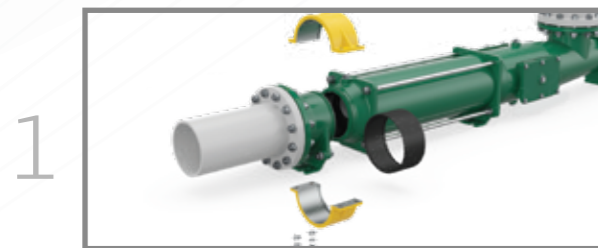

1

Unscrew the clamp and slide the boot seal.

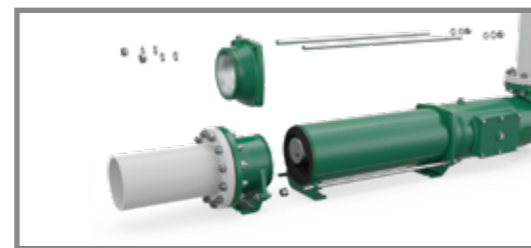

2

Unscrew the hex nuts to remove the end cover flange and tie rods.



3

Unscrew the domed cap nuts to remove the inspection window and gasket.



4

Slide the seal ring to unscrew hex socket head cap screws to remove split coupling rod and stator assembly.



5

Remove rotor & stator for maintenance.

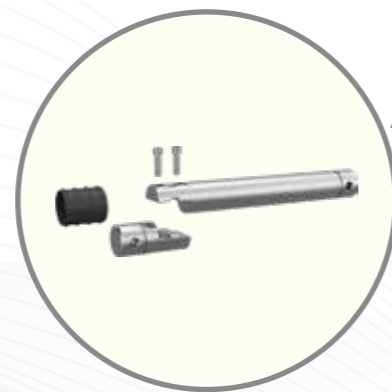

Performance Curves

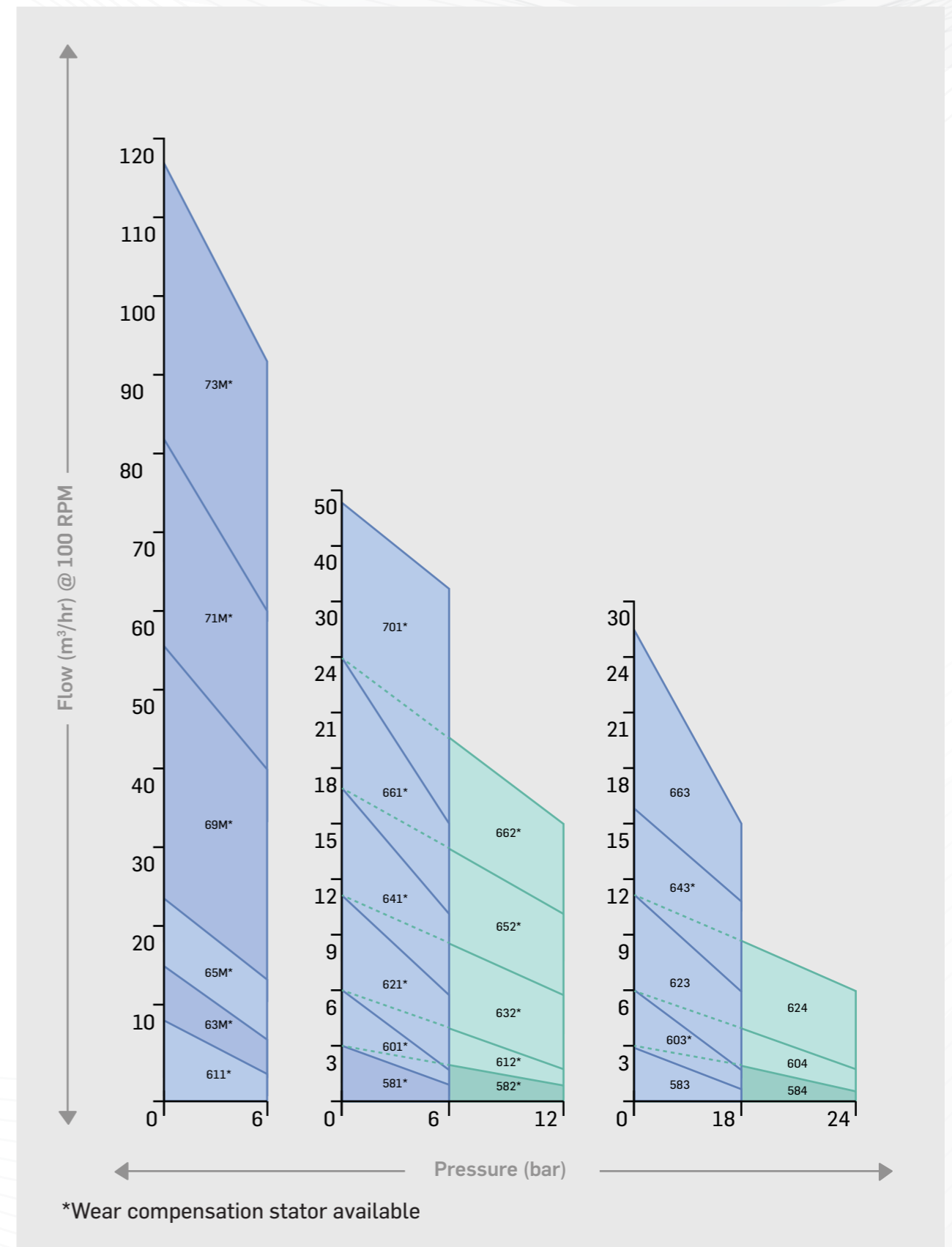

Presenting Uniquely Designed Wear Compensation Stator



Roto's unique Wear Compensation Stator design allows to control and regulate the efficiency of Progressive Cavity Pumps for an extended period. It uses spacers (White, Yellow and Red colors) of engineered lengths to maintain even interference throughout the length of rotor and stator.

It prevents fast wear of the pumping elements (Stator & Rotor) or pump seizure and/or excessive power consumption due to unregulated adjustments. This results in improved volumetric efficiency, which is archived through regulated adjustments.

*Roto KWIK Pumps are supplied with normal stator as a standard. Wear Compensation Stator is available as an added option with additional cost for abrasive and arduous applications.

Assembly Procedure

Over a period of time, the stator wears out, resulting in low flow & pressure.

- 1** Unscrew all nuts to remove the White Spacers, Hex, Head Screws with Washers. Insert the Yellow Spacers, Hex. Head screws with Washers and tighten the Nuts by applying equal torque.
- 2** After some time, the stator may again wear out, resulting in less flow and efficiency of the pump. Then, replace the Yellow Spacers with the Red Spacers.



Industries We Serve



Wastewater



Oil & Gas



Sugar



Biogas



Paper



Paint & Varnish



Marine & Shipbuilding



Mining & Explosives



Roto Pumps Ltd., UK

www.rotopumps.com

NORDITEC

Norditec Equipments AS

Wilber Quintanilla

Sales Engineer

Tel.: +47 988 98 479

wilber@norditec.no

www.norditec.no