

# E1-HP 1" & E2-HP 2"

FULL FLOW HIGH-PRESSURE PUMPS

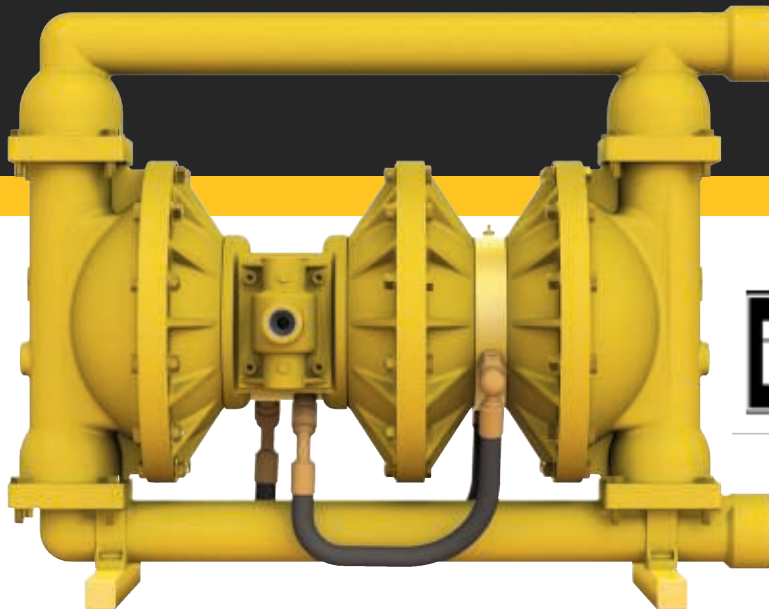

**NORDITEC**

[www.norditec.no](http://www.norditec.no)

- Filter Press Feed
- Mine Dewatering
- Slurry Transfer
- High-Pressure Discharge
- Ceramic Slip & Glaze Spraying / Transfer
- Paints & Coating - Long Run Solvent Transfer & Multiple Discharge Locations
- Automotive - Viscous Lubricant Transfer
- Oil & Gas - Chemical Injection Into Pressurized Lines

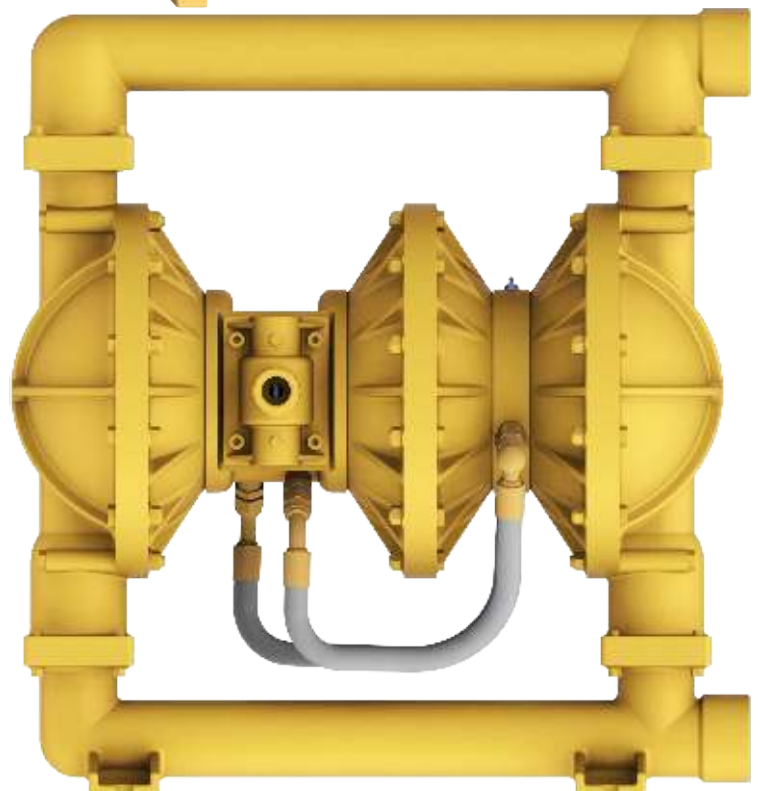

**VERSAMATIC.COM**



**VERSAMATIC®**  
PUMPING MADE EASY

# E1-HP 1" (25 MM) FULL FLOW

- Discharge pressures up to 232 PSI (16 Bar)
- Broadest array of sizes and material options in its class
  - Either Aluminum or Stainless Steel Wetted components, both with Aluminum center sections and Stainless Steel Seats
  - Diaphragms & Check Valves available in: Neoprene, Nitrile/Buna, 2-pc PTFE, or Santoprene
- Full Flow design reduces pulsation and increases productivity and flow rate flexibility
- Can start at zero head with no issues, eliminating the need for an addition fill pump
- Rugged leak free bolted design
- Comes standard with a robust stainless steel air valve

## PERFORMANCE

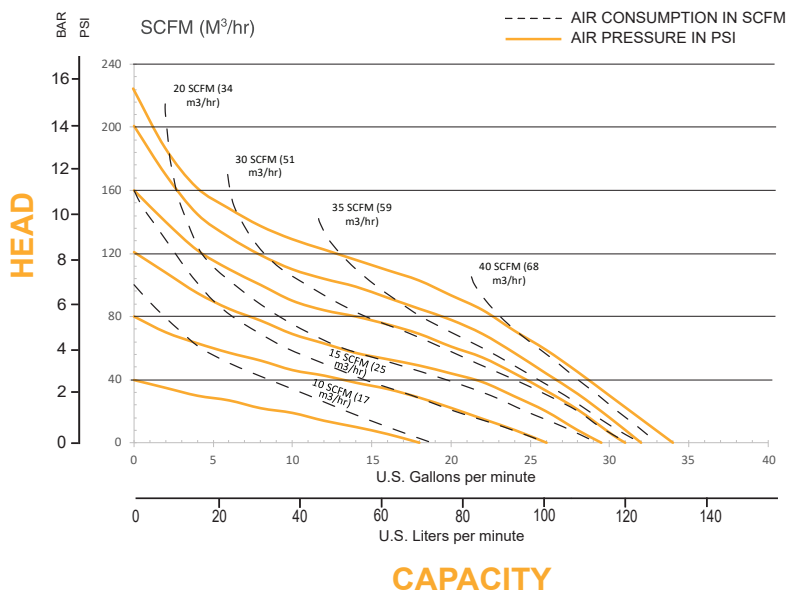

### FLOW RATE

Adjustable to 0-33 gpm (0-125 lpm)

### PORT SIZE

Inlet and Outlet 1" FNPT or FBSPT

### AIR INLET

3/8" NPTF

### AIR EXHAUST

1/2" BSP

### SUCTION LIFT

Dry 20' (6.0 m)

Wet 25' (7.6 m)

### MAX. PARTICLE SIZE

Diameter 0.12" (3mm)

### SHIPPING WEIGHT

Aluminum 52.2 lbs (25.5 kg)

Stainless Steel 76.1 lbs (34.5 kg)

## DIMENSIONS

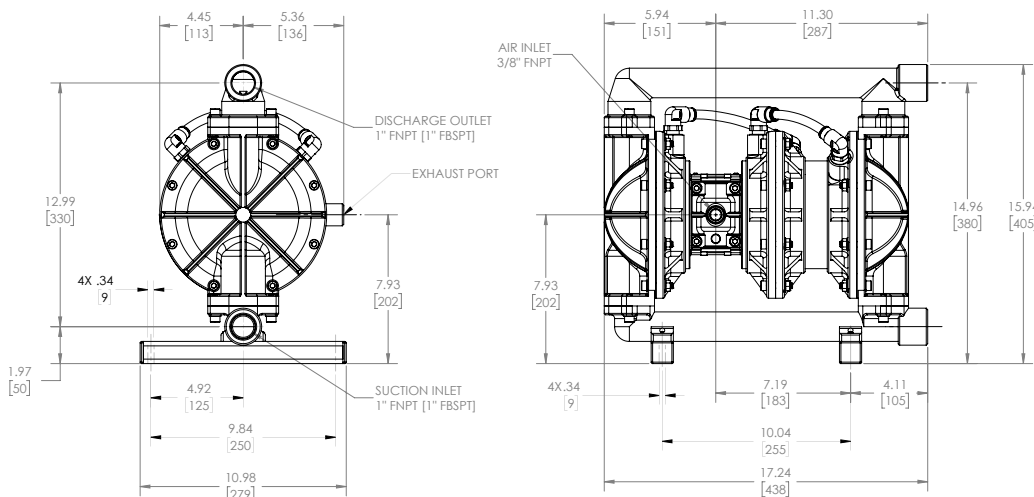

# E2-HP 2" (50 MM) FULL FLOW

- Pressures up to 232 PSI (16 Bar)
- Broadest array of sizes and material options in its class
  - Either Aluminum or Stainless Steel Wetted components, both with Aluminum center sections and Stainless Steel Seats
  - Diaphragms & Check Valves available in: Neoprene, Nitrile/Buna, 2-pc PTFE, or Santoprene
- Full Flow design reduces pulsation and increases productivity and flow rate flexibility
- Can start at zero head with no issues, eliminating the need for an addition fill pump
- Rugged leak free bolted design
- Comes standard with a robust stainless steel air valve
- Can be fitted with a wide array of elastomer's such as: Nitrile, Neoprene, Santoprene, PTFE

## PERFORMANCE

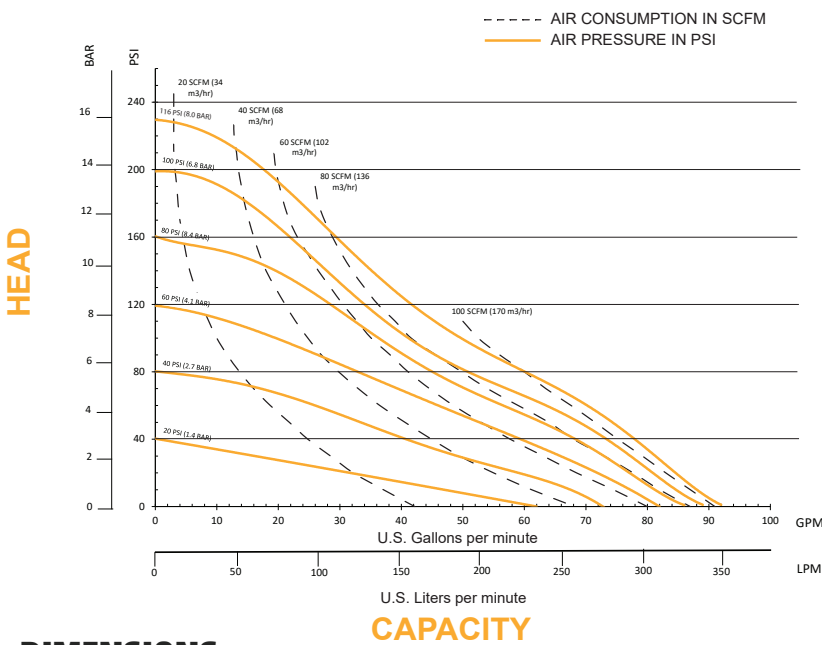

### FLOW RATE

Adjustable to 0-92 gpm (0-348 lpm)

### PORT SIZE

Inlet and Outlet 2" FNPT or FBSPT

### AIR INLET

3/4" NPTF

### AIR EXHAUST

3/4" BSP

### SUCTION LIFT

Dry 20' (6.0 m)

Wet 25' (7.6 m)

### MAX. PARTICLE SIZE

Diameter 0.25" (6mm)

### SHIPPING WEIGHT

Aluminum 113 lbs (51.5 kg)

Stainless Steel 165.3 lbs (75 kg)

## DIMENSIONS

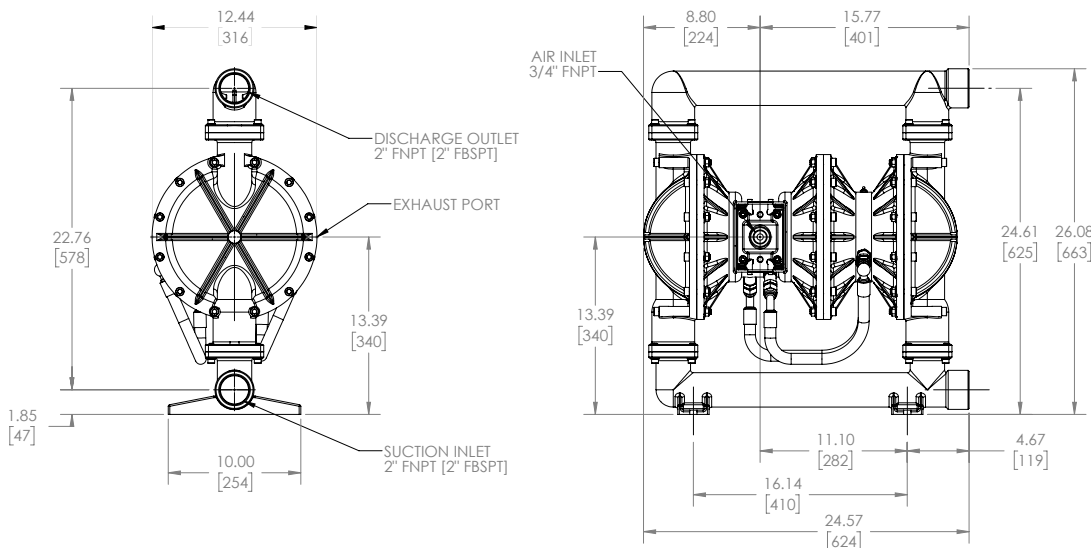

## WHEN THE PRESSURE IS ON, TURN TO OUR HIGH-PRESSURE PUMPS

When you're pumping in a pressurized situation, you need more power than a standard air-operated double diaphragm pump can deliver. That's where the Versamatic line of high-pressure pumps takes over. Providing pressures of up to 235 PSI (16 Bar), our pumps can tackle any application, including filter press feeds, mine dewatering, slurry transfer and high-pressure discharge.

We've assembled the most complete line of high-pressure pumps in the industry. We provide you more options in terms of size, pressure, flow rates, materials of construction and functionality.

No matter which pump fits your need, you'll enjoy an unsurpassed level of reliability. Our pumps feature innovative air-valve systems that eliminate stalling, icing, and costly air leakage and help extend the life of your pump.

### THE RIGHT PUMP FOR THE RIGHT FLOW

Maximum Flow in Gallons Per Minute (lpm)

E1-HP 33 (125)

E2-HP 92 (348)

## HIGH-PRESSURE PUMP ACCESSORIES



### LIQUID LEVEL CONTROL

Versamatic's float actuated Liquid Level Control unit automatically opens and closes air supply to your pump.



### FILTER/REGULATOR

Optimize pump performance and reduce maintenance costs. Filters particles and water out of the compressed air inlet, and controls air pressure. Filter and regulator available as sets or individually.



VERSAMATIC.COM



VM\_BRO\_HighPressurePumps\_Rev1121

©Copyright 2022 Warren Rupp, Inc. All Rights Reserved.